

# Atlas Copco Instruction Manual



User and maintenance manual for  
Portable Energy Storage System  
English

**ZBP 2000**

*Atlas Copco*



**User and maintenance manual for  
Energy Storage System**

**ZBP 2000**

**Original instructions**

Printed matter No.  
2960 8820 00

08/2023



---

ATLAS COPCO - POWER AND FLOW DIVISION  
[www.atlascopco.com](http://www.atlascopco.com)

---

### **Warranty and Liability Limitation**

Use only authorized parts.

Any damage or malfunction caused by the use of unauthorized parts is not covered by Warranty or Product Liability.

The manufacturer does not accept any liability for any damage arising from modifications, additions or conversions made without the manufacturer's approval in writing.

Neglecting maintenance or making changes to the setup of the machine can result in major hazards, including fire risk.

While every effort has been made to ensure that the information in this manual is correct, Atlas Copco does not assume responsibility for possible errors.

Copyright 2023, Atlas Copco (Wuxi) Compressor Co., Ltd.

Any unauthorized use or copying of the contents or any part thereof is prohibited.

This applies in particular to trademarks, model denominations, part numbers and drawings.

## Preface

*Congratulations on the purchase of your Energy Storage System, from now on ESS, based on batteries. It is a solid, safe and reliable machine, built according to the latest technology. Follow the instructions in this booklet and we guarantee you years of trouble free operation. Please read the following instructions carefully before starting to use your machine.*

*While every effort has been made to ensure that the information in this manual is correct, Atlas Copco does not assume responsibility for possible errors. Atlas Copco reserves the right to make changes without prior notice.*

## Table of contents

<b>1</b>	<b>Safety precautions .....</b>	<b>6</b>	3.3.2	Output AC .....	19
1.1	Safety notes .....	6	3.3.3	Output DC .....	19
1.2	Disposal safety instructions .....	6	3.3.4	Input AC (AC recharging) .....	19
<b>2</b>	<b>Main parts .....</b>	<b>7</b>	3.3.5	Input PV (solar energy recharging).....	19
2.1	General description .....	7	3.3.6	Storage.....	20
2.2	Product introduction .....	8	3.3.7	Operating condition.....	20
2.3	Dimension drawing - 9829 3701 60-01 .....	11	3.3.8	load capacity.....	20
2.4	Accessories list .....	12	3.3.9	Battery specifications .....	21
<b>3</b>	<b>Product specification parameters .....</b>	<b>13</b>	3.4	ZBP 2000 UK technical specifications .....	22
3.1	ZBP 2000 AUS technical specifications ....	13	3.4.1	General .....	22
3.1.1	General .....	13	3.4.2	Output AC .....	22
3.1.2	Output AC .....	13	3.4.3	Output DC .....	22
3.1.3	Output DC .....	13	3.4.4	Input AC (AC recharging) .....	22
3.1.4	Input AC (AC recharging).....	13	3.4.5	Input PV (solar energy recharging).....	22
3.1.5	Input PV (solar energy recharging).....	13	3.4.6	Storage.....	23
3.1.6	Storage.....	14	3.4.7	Operating condition.....	23
3.1.7	Operating condition .....	14	3.4.8	load capacity.....	23
3.1.8	load capacity.....	14	3.4.9	Battery specifications .....	24
3.1.9	Battery specifications .....	15	3.5	ZBP 2000 UL technical specifications .....	25
3.2	ZBP 2000 CE technical specifications .....	16	3.5.1	General .....	25
3.2.1	General .....	16	3.5.2	Output AC .....	25
3.2.2	Output AC .....	16	3.5.3	Output DC .....	25
3.2.3	Output DC .....	16	3.5.4	Input AC (AC recharging) .....	25
3.2.4	Input AC (AC recharging).....	16	3.5.5	Input PV (solar energy recharging).....	25
3.2.5	Input PV (solar energy recharging).....	16	3.5.6	Storage.....	26
3.2.6	Storage.....	17	3.5.7	Operating condition.....	26
3.2.7	Operating condition .....	17	3.5.8	load capacity.....	26
3.2.8	load capacity.....	17	3.5.9	Battery specifications .....	27
3.2.9	Battery specifications .....	18	<b>4</b>	<b>Operations .....</b>	<b>28</b>
3.3	ZBP 2000 CN technical specifications .....	19	4.1	Start up .....	28
3.3.1	General .....	19	4.2	Charging .....	29
			4.3	Solar charging .....	29
			4.4	Parallel operation .....	30
			4.5	AC output .....	30

4.6	USB output .....	31
4.7	Overload protection .....	31
4.8	WI-FI mobile control .....	31
4.9	Machine abnormalities operations .....	32
4.10	Shut down .....	32
<b>5</b>	<b>Maintenance .....</b>	<b>33</b>
5.1	<b>Maintenance Schedule .....</b>	<b>33</b>
5.2	Performance maintenance for battery .....	35

# Safety precautions

 To be read attentively and acted accordingly before towing, lifting, operating, performing maintenance or repairing the ESS.

## SAFETY NOTES

Do not use this product near heat source, such as fire or electric ovens.

Do not use this product upright, it will cause the air tunnel towards the ground blocking the air inlet and outlet.

Please do not use this product in heavy rain or stormy weather. Underwater use is strictly prohibited.

Do not use this product in static electricity or strong magnetic field environment.

Do not disassemble this product in any way, please contact after-sales or local distributor for any problems.

Do not use unapproved accessories, if you need to replace or purchase accessories, please contact Atlas Copco.

Please be sure to follow the ambient temperature specified in this manual. If the temperature is too high, it may lead to fire or explosion. If the temperature is too low, the product performance may be degraded or not work.

Please avoid violent impact, drop or vibration of the shell. In case of violent vibration or shock, please cut off the power and stop using the product. Please fix the machine firmly during transportation to prevent violent vibration or impact.

Do not use in unventilated, strongly dusty environments.

## DISPOSAL SAFETY INSTRUCTIONS

If it is permitted, please discharge the battery completely and dispose of it in a proper battery recycling bin, this product contains hazardous chemicals, therefore, do not discard the product in the ordinary rubbish bin. Please refer to the local laws and regulations regarding the recycling and disposal of batteries.

If the battery cannot be fully discharged due to a failure, do not discard it directly in the battery recycling bin. You should contact a company that specializes in battery recycling for further processing.

# Main parts

## GENERAL DESCRIPTION

The Atlas Copco ZBP 2000 is a new industrial-grade portable energy storage power supply. It has a single-unit capacity of 2 kilowatt-hours and uses lithium iron phosphate batteries. It has high energy density and stable and safe performance. With a retractable rod and wheels, the portability and flexibility are greatly improved. The design of 5 units that can be paralleled continuously can fully meet the electricity demand for production and life such as outdoor construction, industrial emergency, special equipment and vehicle backup.





PRODUCT INTRODUCTION

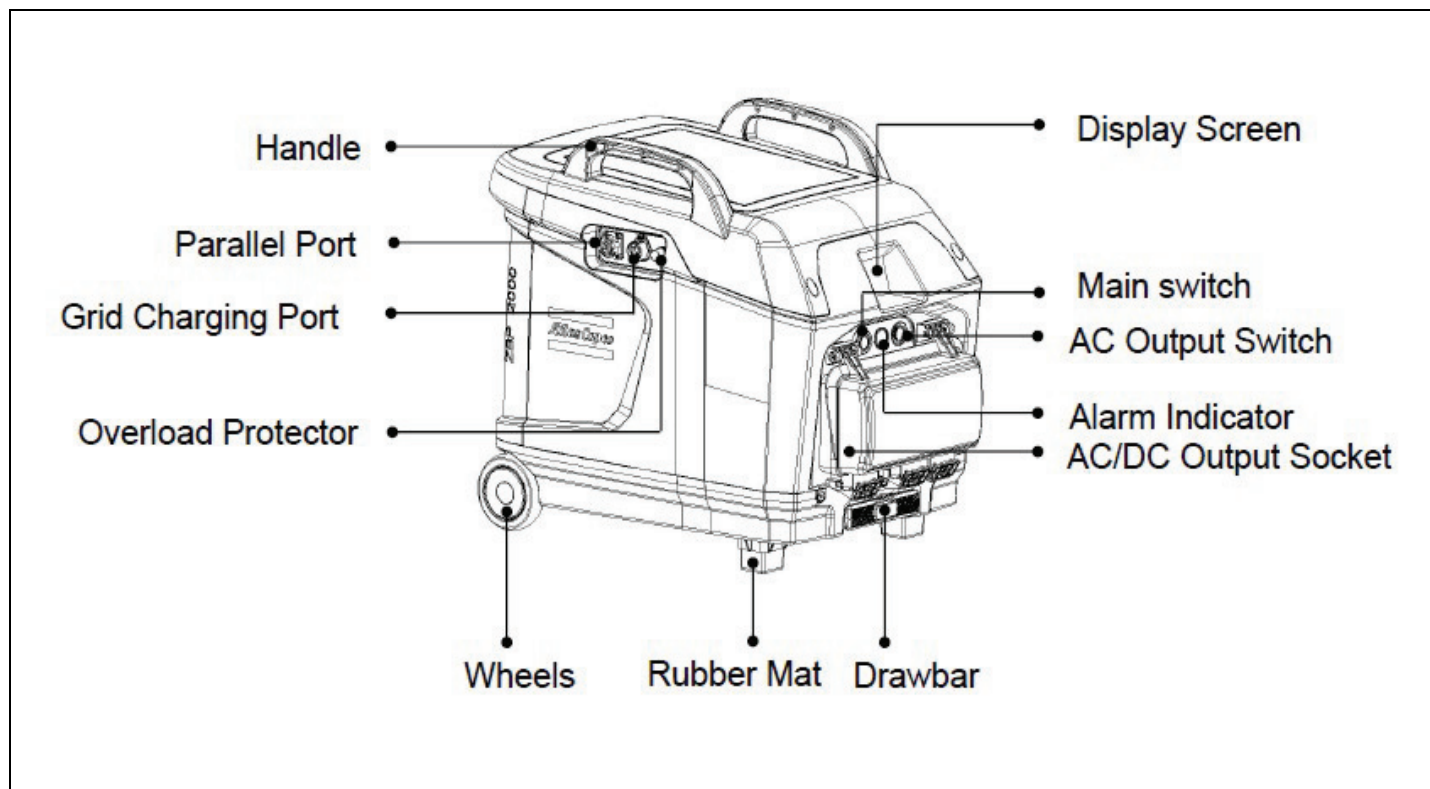

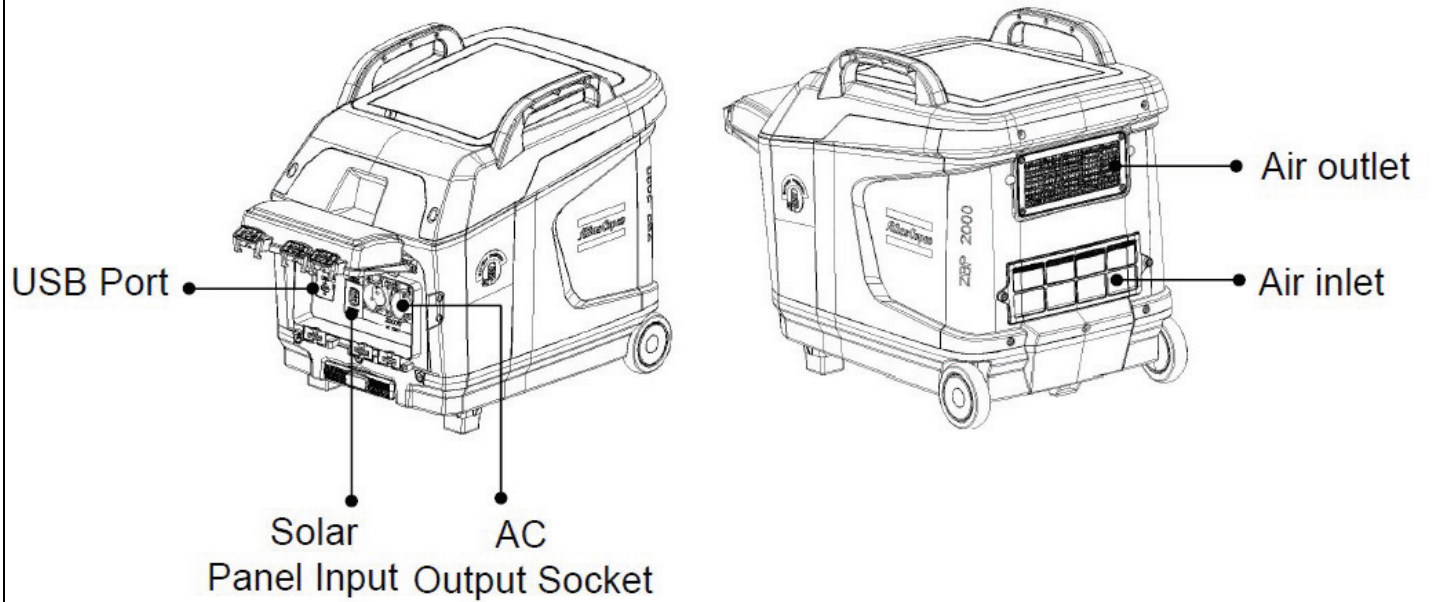

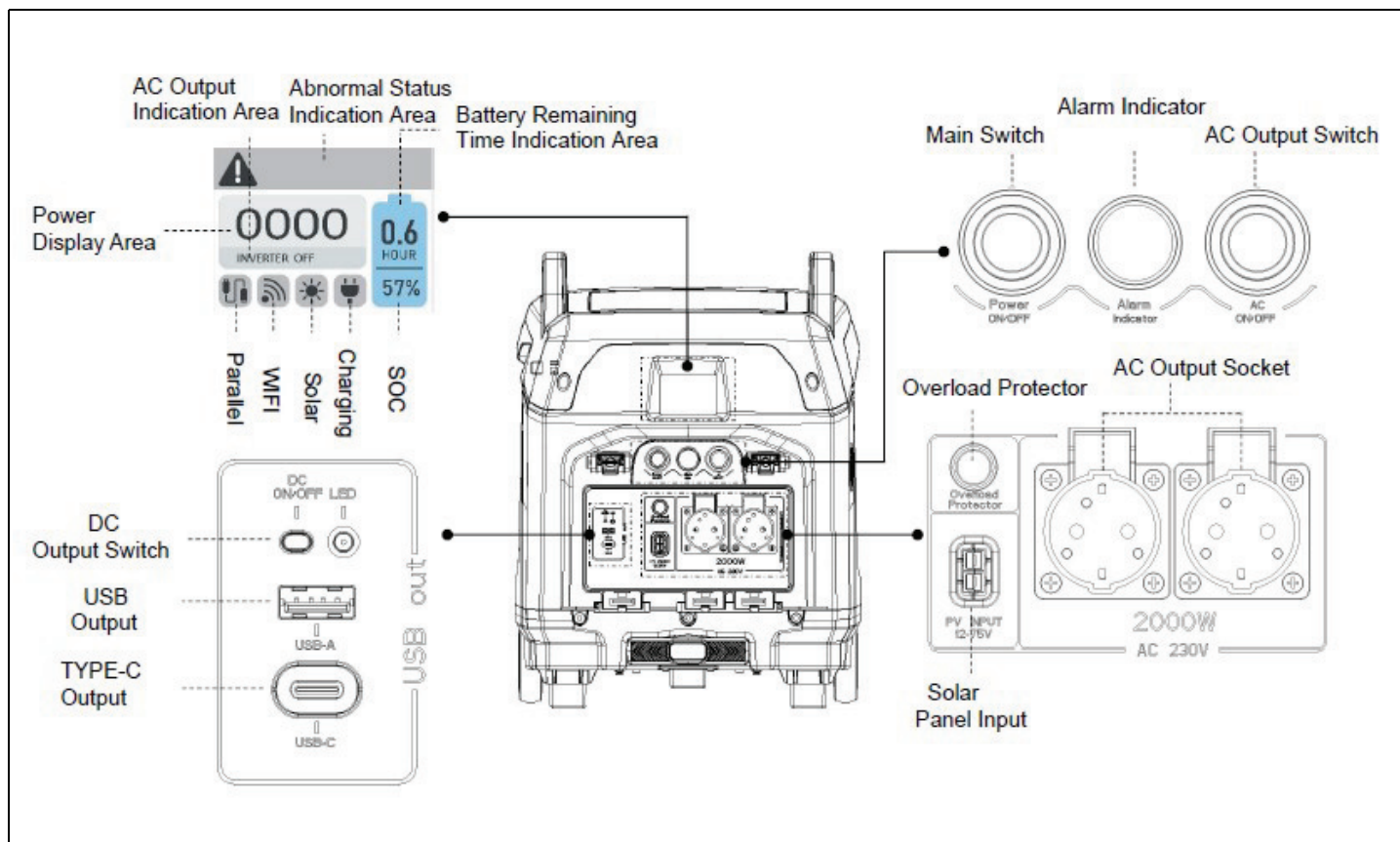

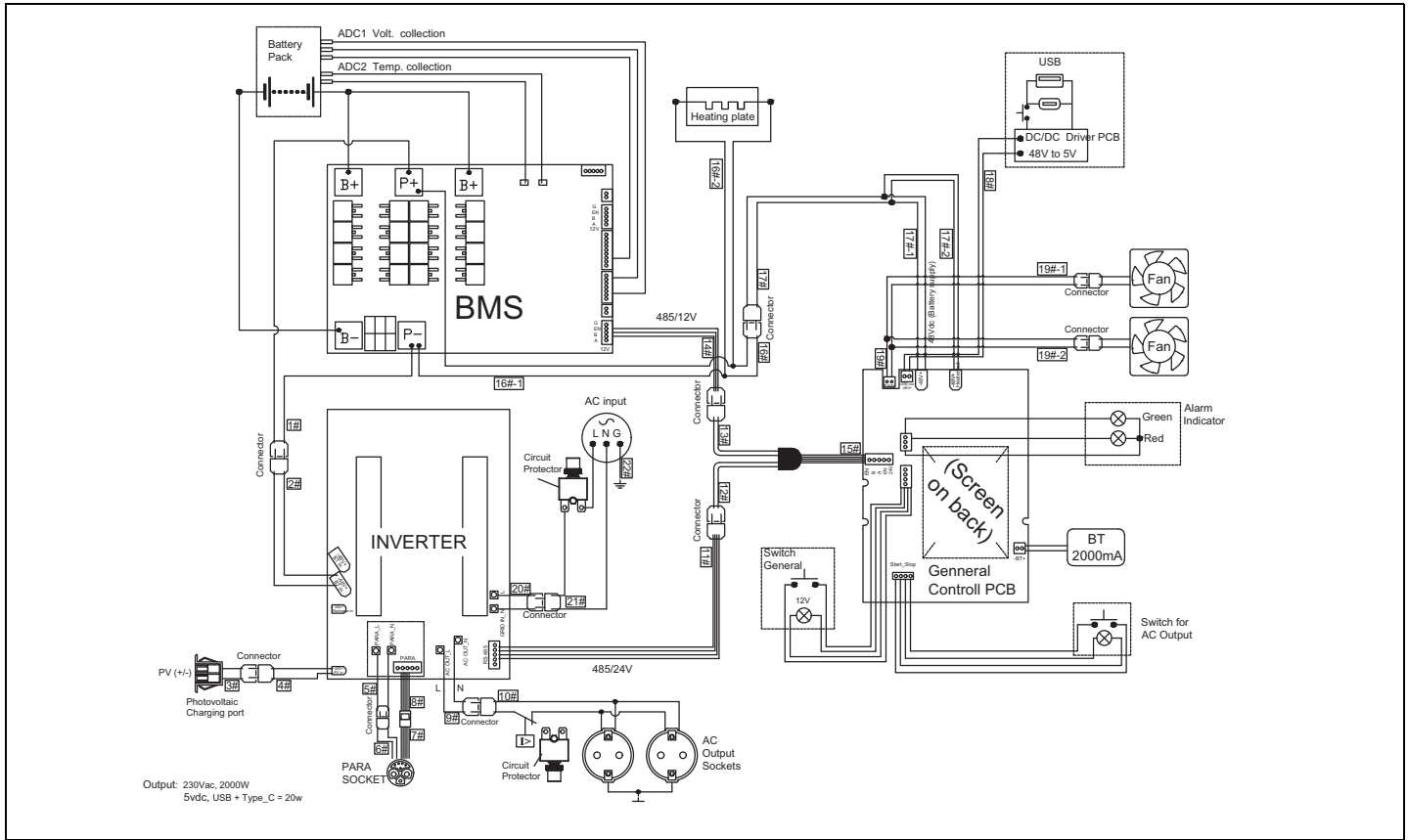

**DIMENSION DRAWING - 9829 3701 60-01**

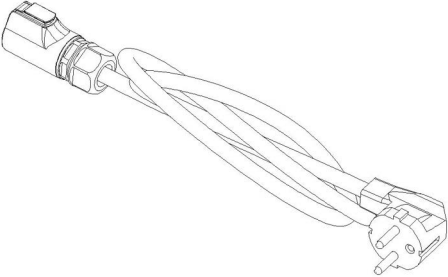

## ACCESSORIES LIST

Below items are provided with the ZBP 2000 ESS unit.

Item	Picture	Quantity
Charging Cable		1
Manual		1

# Product specification parameters

## ZBP 2000 AUS TECHNICAL SPECIFICATIONS

### GENERAL

Parameter/Item	Value/Description	Remarks
Capacity	2 kWh	
Rated power	2 kVA	
Full power efficiency	≥ 95%	
Charging time	About 3 hours	Ambient temperature 25°C
Weight	≈ 81.58 lbs / 37 kg	
Battery type	LFP battery	
Dimension	570x367x478 mm	
Protection rating	IP 55 / IK 09	
Certificates	SAA (TBD)	

### OUTPUT AC

Parameter/Item	Value/Description	Remarks
Rated output voltage	240VAC±4%	
Rated frequency	50Hz	
Rated current	9A	
Output socket	15A	
Parallel charger socket	15A	
Max parallel machine numbers	5 machines	

### OUTPUT DC

Parameter/Item	Value/Description	Remarks
USB category	USB-Ax1, Type-Cx1	
Rated output voltage	5Vdc/9Vdc/12Vdc 18W Max	
Use simultaneously	5Vdc 10W Max	

### INPUT AC (AC RECHARGING)

Parameter/Item	Value/Description	Remarks
Input voltage (VAC)	240 VAC±10%	
Charging input current (RMS)	≤ 4.5A	

### INPUT PV (SOLAR ENERGY RECHARGING)

Parameter/Item	Value/Description	Remarks
Input voltage (VAC)	12V~60V	
Charging input current (RMS)	≤ 15A	
Charging power	≤ 800 W	

## STORAGE

Parameter/Item	Value/Description	Remarks
Storage temperature	-20°C ~ +45°C (3 months)	
	-10°C ~ +25°C (6 months)	
Storage humidity	≤ 75%	No condensation

- 1) This device is intended to be stored indoors and shall not be stored or left outdoors when not in use.
- 2) After the user receives the product, please conduct a charge-discharge cycle operation at the first time.
- 3) If the SOC is less than 10%, please make sure to charge it within 7 days.
- 4) If the battery is stored for a long time (SOC>50%), turn off the power switch and it is required to do a charge-discharge cycle every 6 months (fully charge-fully discharge-recharge to SOC 50%).

## OPERATING CONDITION

Parameter/Item	Value/Description	Remarks
Charging temperature	0°C ~ +45°C	Ambient temperature
Storage temperature	-20°C ~ +45°C	Ambient temperature
Cycle life	≥ 2000 Cycles of charging and discharging, battery capacity ≥ 80%	Ambient temperature 25°C
Relative humidity	≤ 75%	No condensation

## LOAD CAPACITY

Parameter/Item	Value/Description	Remarks
Load current	< 105%	Continuous operation
Load current	105% ~ 130%	Operating time < 1min
Load current	130% ~ 200%	Operating time < 500ms
Load current	> 200%	Operating time < 200 ms
Voltage transient (load 0 ↔ 100%)	<10%	
Transient recovery time	<100 ms	

## BATTERY SPECIFICATIONS

Parameter/Item	Value/Description	Remarks
Rated voltage	48VDC	
Operating voltage	40-54.3VDC	
Charging time	≤ 3 hours	Ambient temperature 25°C
Discharging power	≤ 1000W (Reduced power usage)	Battery operating temperature -20°C ~ 0°C
	≤ 1000W (Reduced power usage)	Battery operating temperature 0°C ~ 15°C
	≤ 2000W	Battery operating temperature 15°C ~ 40°C
	≤ 1000W (Reduced power usage)	Battery operating temperature 40°C ~ 45°C
SOC	45Ah Ambient temperature 25°C	Battery operation temperature 55°C: ≥ 95%
		Battery operation temperature -10°C: ≥ 70%



## ZBP 2000 CE TECHNICAL SPECIFICATIONS

### GENERAL

Parameter/Item	Value/Description	Remarks
Capacity	2 kWh	
Rated power	2 kVA	
Full power efficiency	≥ 95%	
Charging time	About 3 hours	Ambient temperature 25°C
Weight	≈ 81.58 lbs / 37 kg	
Battery type	LFP battery	
Dimension	570x367x478 mm	
Protection rating	IP 55 / IK 09	
Certificates	CE	

### OUTPUT AC

Parameter/Item	Value/Description	Remarks
Rated output voltage	230VAC±4%	
Rated frequency	50Hz	
Rated current	9A	
Output socket	16A	
Parallel charger socket	16A	
Max parallel machine numbers	5 machines	

### OUTPUT DC

Parameter/Item	Value/Description	Remarks
USB category	USB-Ax1, Type-Cx1	
Rated output voltage	5Vdc/9Vdc/12Vdc 18W Max	
Use simultaneously	5Vdc 10W Max	

### INPUT AC (AC RECHARGING)

Parameter/Item	Value/Description	Remarks
Input voltage (VAC)	230 VAC±10%	
Charging input current (RMS)	≤ 4.5A	

### INPUT PV (SOLAR ENERGY RECHARGING)

Parameter/Item	Value/Description	Remarks
Input voltage (VAC)	12V~60V	
Charging input current (RMS)	≤ 15A	
Charging power	≤ 800 W	

## STORAGE

Parameter/Item	Value/Description	Remarks
Storage temperature	-20°C ~ +45°C (3 months)	
	-10°C ~ +25°C (6 months)	
Storage humidity	≤ 75%	No condensation

- 1) This device is intended to be stored indoors and shall not be stored or left outdoors when not in use.
- 2) After the user receives the product, please conduct a charge-discharge cycle operation at the first time.
- 3) If the SOC is less than 10%, please make sure to charge it within 7 days.
- 4) If the battery is stored for a long time (SOC>50%), turn off the power switch and it is required to do a charge-discharge cycle every 6 months (fully charge-fully discharge-recharge to SOC 50%).

## OPERATING CONDITION

Parameter/Item	Value/Description	Remarks
Charging temperature	0°C ~ +45°C	Ambient temperature
Storage temperature	-20°C ~ +45°C	Ambient temperature
Cycle life	≥ 2000 Cycles of charging and discharging, battery capacity ≥ 80%	Ambient temperature 25°C
Relative humidity	≤ 75%	No condensation

## LOAD CAPACITY

Parameter/Item	Value/Description	Remarks
Load current	< 105%	Continuous operation
Load current	105% ~ 130%	Operating time < 1min
Load current	130% ~ 200%	Operating time < 500ms
Load current	> 200%	Operating time < 200 ms
Voltage transient (load 0 ↔ 100%)	<10%	
Transient recovery time	<100 ms	

## BATTERY SPECIFICATIONS

Parameter/Item	Value/Description	Remarks
Rated voltage	48VDC	
Operating voltage	40-54.3VDC	
Charging time	≤ 3 hours	Ambient temperature 25°C
Discharging power	≤ 1000W (Reduced power usage)	Battery operating temperature -20°C ~ 0°C
	≤ 1000W (Reduced power usage)	Battery operating temperature 0°C ~ 15°C
	≤ 2000W	Battery operating temperature 15°C ~ 40°C
	≤ 1000W (Reduced power usage)	Battery operating temperature 40°C ~ 45°C
SOC	45Ah Ambient temperature 25°C	Battery operation temperature 55°C: ≥ 95%
		Battery operation temperature -10°C: ≥ 70%

## ZBP 2000 CN TECHNICAL SPECIFICATIONS

### GENERAL

Parameter/Item	Value/Description	Remarks
Capacity	2 kWh	
Rated power	2 kVA	
Full power efficiency	≥ 95%	
Charging time	About 3 hours	Ambient temperature 25°C
Weight	≈ 81.58 lbs / 37 kg	
Battery type	LFP battery	
Dimension	570x367x478 mm	
Protection rating	IP 55 / IK 09	
Certificates	SAA (TBD)	

### OUTPUT AC

Parameter/Item	Value/Description	Remarks
Rated output voltage	220VAC±4%	
Rated frequency	50Hz	
Rated current	9A	
Output socket	10A/16A	
Parallel charger socket	10A/16A	
Max parallel machine numbers	5 machines	

### OUTPUT DC

Parameter/Item	Value/Description	Remarks
USB category	USB-Ax1, Type-Cx1	
Rated output voltage	5Vdc/9Vdc/12Vdc 18W Max	
Use simultaneously	5Vdc 10W Max	

### INPUT AC (AC RECHARGING)

Parameter/Item	Value/Description	Remarks
Input voltage (VAC)	220 VAC±10%	
Charging input current (RMS)	≤ 4.5A	

### INPUT PV (SOLAR ENERGY RECHARGING)

Parameter/Item	Value/Description	Remarks
Input voltage (VAC)	12V~60V	
Charging input current (RMS)	≤ 15A	
Charging power	≤ 800 W	

## STORAGE

Parameter/Item	Value/Description	Remarks
Storage temperature	-20°C ~ +45°C (3 months)	
	-10°C ~ +25°C (6 months)	
Storage humidity	≤ 75%	No condensation

1) This device is intended to be stored indoors and shall not be stored or left outdoors when not in use.

2) After the user receives the product, please conduct a charge-discharge cycle operation at the first time.

3) If the SOC is less than 10%, please make sure to charge it within 7 days.

4) If the battery is stored for a long time (SOC>50%), turn off the power switch and it is required to do a charge-discharge cycle every 6 months (fully charge-fully discharge-recharge to SOC 50%).

## OPERATING CONDITION

Parameter/Item	Value/Description	Remarks
Charging temperature	0°C ~ +45°C	Ambient temperature
Storage temperature	-20°C ~ +45°C	Ambient temperature
Cycle life	≥ 2000 Cycles of charging and discharging, battery capacity ≥ 80%	Ambient temperature 25°C
Relative humidity	≤ 75%	No condensation

## LOAD CAPACITY

Parameter/Item	Value/Description	Remarks
Load current	< 105%	Continuous operation
Load current	105% ~ 130%	Operating time < 1min
Load current	130% ~ 200%	Operating time < 500ms
Load current	> 200%	Operating time < 200 ms
Voltage transient (load 0 ↔ 100%)	<10%	
Transient recovery time	<100 ms	

## BATTERY SPECIFICATIONS

Parameter/Item	Value/Description	Remarks
Rated voltage	48VDC	
Operating voltage	40-54.3VDC	
Charging time	≤ 3 hours	Ambient temperature 25°C
Discharging power	≤ 1000W (Reduced power usage)	Battery operating temperature -20°C ~ 0°C
	≤ 1000W (Reduced power usage)	Battery operating temperature 0°C ~ 15°C
	≤ 2000W	Battery operating temperature 15°C ~ 40°C
	≤ 1000W (Reduced power usage)	Battery operating temperature 40°C ~ 45°C
SOC	45Ah Ambient temperature 25°C	Battery operation temperature 55°C: ≥ 95%
		Battery operation temperature -10°C: ≥ 70%

## ZBP 2000 UK TECHNICAL SPECIFICATIONS

### GENERAL

Parameter/Item	Value/Description	Remarks
Capacity	2 kWh	
Rated power	2 kVA	
Full power efficiency	≥ 95%	
Charging time	About 3 hours	Ambient temperature 25°C
Weight	≈ 81.58 lbs / 37 kg	
Battery type	LFP battery	
Dimension	570x367x478 mm	
Protection rating	IP 55 / IK 09	
Certificates	UKCA	

### OUTPUT AC

Parameter/Item	Value/Description	Remarks
Rated output voltage	240VAC±4%	
Rated frequency	50Hz	
Rated current	9A	
Output socket	13A	
Parallel charger socket	13A	
Max parallel machine numbers	5 machines	

### OUTPUT DC

Parameter/Item	Value/Description	Remarks
USB category	USB-Ax1, Type-Cx1	
Rated output voltage	5Vdc/9Vdc/12Vdc 18W Max	
Use simultaneously	5Vdc 10W Max	

### INPUT AC (AC RECHARGING)

Parameter/Item	Value/Description	Remarks
Input voltage (VAC)	240 VAC±10%	
Charging input current (RMS)	≤ 4.5A	

### INPUT PV (SOLAR ENERGY RECHARGING)

Parameter/Item	Value/Description	Remarks
Input voltage (VAC)	12V~60V	
Charging input current (RMS)	≤ 15A	
Charging power	≤ 800 W	

## STORAGE

Parameter/Item	Value/Description	Remarks
Storage temperature	-20°C ~ +45°C (3 months)	
	-10°C ~ +25°C (6 months)	
Storage humidity	≤ 75%	No condensation

- 1) This device is intended to be stored indoors and shall not be stored or left outdoors when not in use.
- 2) After the user receives the product, please conduct a charge-discharge cycle operation at the first time.
- 3) If the SOC is less than 10%, please make sure to charge it within 7 days.
- 4) If the battery is stored for a long time (SOC>50%), turn off the power switch and it is required to do a charge-discharge cycle every 6 months (fully charge-fully discharge-recharge to SOC 50%).

## OPERATING CONDITION

Parameter/Item	Value/Description	Remarks
Charging temperature	0°C ~ +45°C	Ambient temperature
Storage temperature	-20°C ~ +45°C	Ambient temperature
Cycle life	≥ 2000 Cycles of charging and discharging, battery capacity ≥ 80%	Ambient temperature 25°C
Relative humidity	≤ 75%	No condensation

## LOAD CAPACITY

Parameter/Item	Value/Description	Remarks
Load current	< 105%	Continuous operation
Load current	105% ~ 130%	Operating time < 1min
Load current	130% ~ 200%	Operating time < 500ms
Load current	> 200%	Operating time < 200 ms
Voltage transient (load 0 ↔ 100%)	<10%	
Transient recovery time	<100 ms	



## BATTERY SPECIFICATIONS

Parameter/Item	Value/Description	Remarks
Rated voltage	48VDC	
Operating voltage	40-54.3VDC	
Charging time	≤ 3 hours	Ambient temperature 25°C
Discharging power	≤ 1000W (Reduced power usage)	Battery operating temperature -20°C ~ 0°C
	≤ 1000W (Reduced power usage)	Battery operating temperature 0°C ~ 15°C
	≤ 2000W	Battery operating temperature 15°C ~ 40°C
	≤ 1000W (Reduced power usage)	Battery operating temperature 40°C ~ 45°C
SOC	45Ah Ambient temperature 25°C	Battery operation temperature 55°C: ≥ 95%
		Battery operation temperature -10°C: ≥ 70%

## ZBP 2000 UL TECHNICAL SPECIFICATIONS

### GENERAL

Parameter/Item	Value/Description	Remarks
Capacity	2 kWh	
Rated power	2 kVA	
Full power efficiency	≥ 95%	
Charging time	About 3 hours	Ambient temperature 25°C
Weight	≈ 81.58 lbs / 37 kg	
Battery type	LFP battery	
Dimension	570x367x478 mm	
Protection rating	IP 55 / IK 09	
Certificates	ETL FCC	

### OUTPUT AC

Parameter/Item	Value/Description	Remarks
Rated output voltage	120VAC±4%	
Rated frequency	50Hz/60Hz	
Rated current	20A	
Output socket	20A	
Parallel charger socket	20A	
Max parallel machine numbers	5 machines	

### OUTPUT DC

Parameter/Item	Value/Description	Remarks
USB category	USB-Ax1, Type-Cx1	
Rated output voltage	5Vdc/9Vdc/12Vdc 18W Max	
Use simultaneously	5Vdc 10W Max	

### INPUT AC (AC RECHARGING)

Parameter/Item	Value/Description	Remarks
Input voltage (VAC)	120 VAC±10%	
Charging input current (RMS)	≤ 9A	

### INPUT PV (SOLAR ENERGY RECHARGING)

Parameter/Item	Value/Description	Remarks
Input voltage (VAC)	12V~60V	
Charging input current (RMS)	≤ 15A	
Charging power	≤ 800 W	

## STORAGE

Parameter/Item	Value/Description	Remarks
Storage temperature	-20°C ~ +45°C (3 months)	
	-10°C ~ +25°C (6 months)	
Storage humidity	≤ 75%	No condensation

1) This device is intended to be stored indoors and shall not be stored or left outdoors when not in use.

2) After the user receives the product, please conduct a charge-discharge cycle operation at the first time.

3) If the SOC is less than 10%, please make sure to charge it within 7 days.

4) If the battery is stored for a long time (SOC>50%), turn off the power switch and it is required to do a charge-discharge cycle every 6 months (fully charge-fully discharge-recharge to SOC 50%).

## OPERATING CONDITION

Parameter/Item	Value/Description	Remarks
Charging temperature	0°C ~ +45°C	Ambient temperature
Storage temperature	-20°C ~ +45°C	Ambient temperature
Cycle life	≥ 2000 Cycles of charging and discharging, battery capacity ≥ 80%	Ambient temperature 25°C
Relative humidity	≤ 75%	No condensation

## LOAD CAPACITY

Parameter/Item	Value/Description	Remarks
Load current	< 105%	Continuous operation
Load current	105% ~ 130%	Operating time < 1min
Load current	130% ~ 200%	Operating time < 500ms
Load current	> 200%	Operating time < 200 ms
Voltage transient (load 0 ↔ 100%)	<10%	
Transient recovery time	<100 ms	

## BATTERY SPECIFICATIONS

Parameter/Item	Value/Description	Remarks
Rated voltage	48VDC	
Operating voltage	40-54.3VDC	
Charging time	≤ 3 hours	Ambient temperature 25°C
Discharging power	≤ 1000W (Reduced power usage)	Battery operating temperature -20°C ~ 0°C
	≤ 1000W (Reduced power usage)	Battery operating temperature 0°C ~ 15°C
	≤ 2000W	Battery operating temperature 15°C ~ 40°C
	≤ 1000W (Reduced power usage)	Battery operating temperature 40°C ~ 45°C
SOC	45Ah Ambient temperature 25°C	Battery operation temperature 55°C: ≥ 95%
		Battery operation temperature -10°C: ≥ 70%

# Operations



Place the ZBP 2000 horizontally and start running, keep the ventilations openings clear and no objects that might obstruct the ventilations.

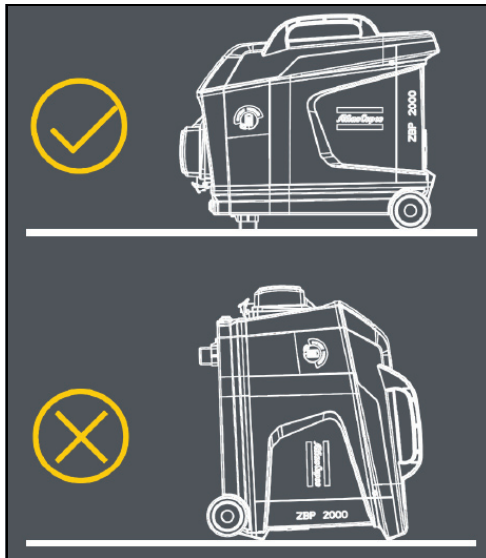

Over-discharging will result in a shortened lithium-ion battery lifetime. Please charge in time when the battery is too low.

## START UP

1. Press the main switch button (1) on the control panel.
2. As the machine turns on, the starting screen (2) appears, the rear fan self-check program starts.
3. 15 seconds later, the screen changes to the user interface view (3).
4. The alarm indicator (4) illuminates in yellow.

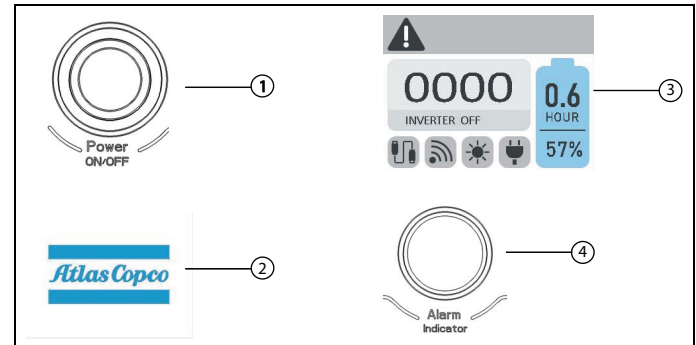

## CHARGING

1. Remove the charging cable from the accessories bag and connect one end to the grid power supply and the other to the grid charging port on the machine's side with a matching plug (1).
2. When the power turns on, the screen displays the charging power, the battery icon background color is green (2) showing the current power and remaining work time and the charging indicator icon on the screen lights up (3).
3. When the battery temperature is in  $-20^{\circ}\text{C} \sim 0^{\circ}\text{C}$ , the battery heating program is started first, and the abnormal status indication area of the screen appears as shown as (4), followed by the battery icon as shown as (5).
4. At this moment, the machine's maximum load is 400W; when the battery temperature falls below  $-20^{\circ}\text{C}$ , the abnormal state indicator area of the screen displays as (6), while the battery icon displays as (7), then the machine will not operate.

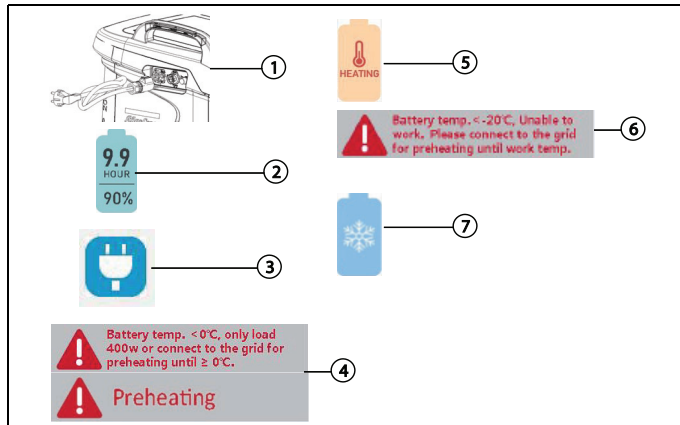

## SOLAR CHARGING

1. Open the front transparent waterproof cover (push the upper part of the three clasps shown in the picture to loosen the buckle, then open front cover) (1).
2. Insert the solar panel connector into the solar input port (2) and the solar indicator on the screen will light up (3).
3. The current solar charging power is visible on the power display area.

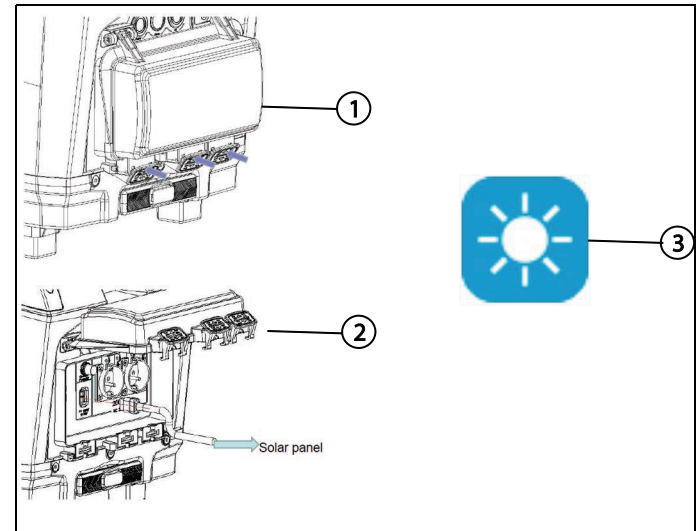

## PARALLEL OPERATION

1. Open the waterproof cover of the parallel socket on the side of the machine
2. Insert one end of the parallel cable (optional accessory) into the machine's parallel socket and the other end into the parallel box (optional accessory) (1).
3. The parallel indicator icon on the screen illuminates (2), and the output power (the average value of the total output power for each machine) appears in the power display area.

For example, total 5 parallel machine, the load of 10 KW, the power of each machine is  $10/5=2\text{KW}\pm 5\%$ .



**ZBP 2000 can achieve up to 5 parallel machines.**

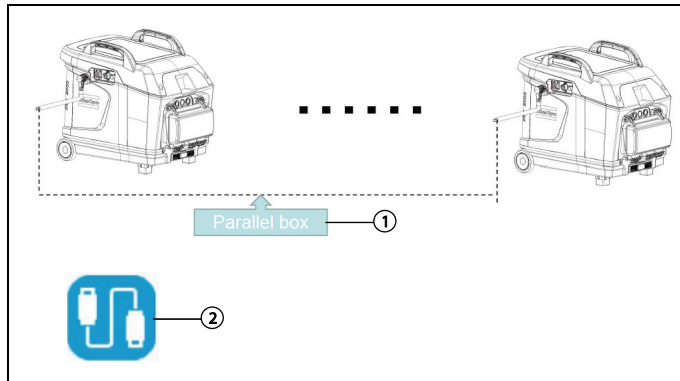

## AC OUTPUT

1. Open the front transparent waterproof cover of the machine.
2. Insert the plug into the AC output socket (1), the maximum output of a single socket is 16A (230V machine), 20A (110V machine).
3. Sort out the plug wire (the wire should be correctly go through the middle of the transparent cover and the buckle).
4. Close the transparent cover and the buckle as shown (2), the transparent waterproof cover can be opened if environment is dry.
5. Press the AC output switch (3), the switch just lights up, the power display area of the screen shows the output power and AC display area shows the output voltage, frequency (4).



**When the machine is charging, the output power is supplied by the grid. The maximum power of the grid is 2400W, the charging power is the maximum power of the grid minus the output power, but the maximum charging power is not more than 1000W.**

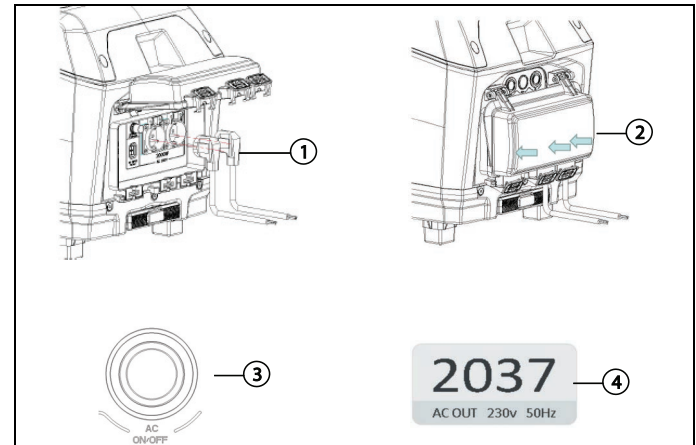

## USB OUTPUT

1. Open the front transparent waterproof cover of the machine.
2. Plug the phone charging cable into the USB-A socket or USB-C socket (according to the configuration of the phone).
3. Long press the DC ON/OFF switch for 2s to turn on the DC charging, the LED indicator lights up (1).
4. Press the DC ON/OFF switch to turn off the USB output.

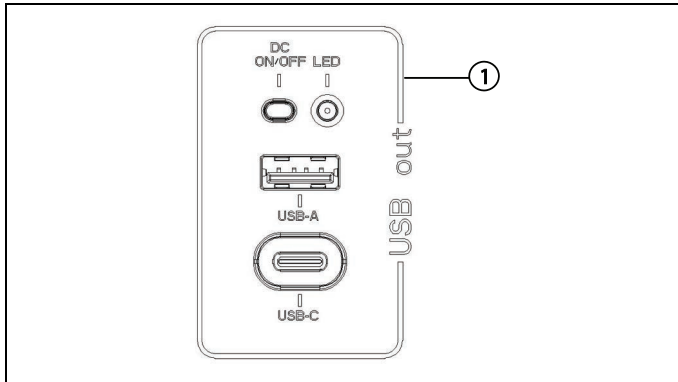

## OVERLOAD PROTECTION

The machine is equipped with overload protection for both grid input and load output (1 and 2), which is used to achieve physical protection in case of software protection failure. When the input or output voltage is too large, the button of overload protector is pop-up. Press the button to restart the machine after the fault is removed.

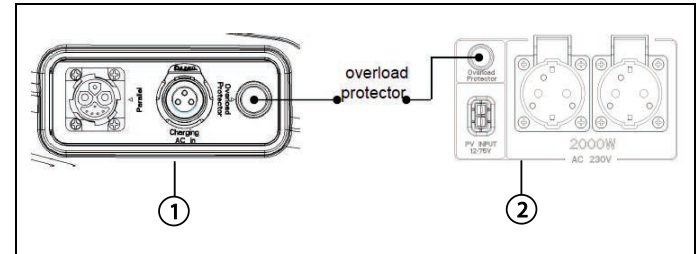



## WI-FI MOBILE CONTROL

1. Turn on the machine and the screen will show the main interface.
2. The machine generates WI-FI signal, connect the smart-phone to the WI-FI (name of this machine) and WI-FI indicator on the screen lights up (1).
3. The smart-phone automatically pops up the control interface (figure to be confirmed) on the screen.
4. It can allow the smart-phone to wirelessly control the machine on/off, AC output on/off and all the information displayed on the machine screen can be viewed simultaneously.



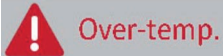

## MACHINE ABNORMALITIES OPERATIONS

Reasons for abnormality	Abnormal status displayed on screen	Solutions
Fan abnormality		Long press the main switch of the machine, replace the fan after shutdown, and restart the machine.
Over-temperature		Wait until the battery temperature drops to 45°C or the temperature of 3 inverters drop to 85°C, 90°C, 110°C or below then machine works normally.
Overload		Long press the main switch to turn off the machine, then reduce the load power (check the overload capacity in the product specification table), restart the machine.
Short circuit		Long press the main switch to turn off the machine, check and eliminate the short-circuit fault, then restart the machine



When multiple abnormalities occur at the same time, the abnormal display area on the screen shows alternately the abnormal causes, and the alarm indicator turns on in red.

## SHUT DOWN

1. Long press main switch button on the front cover for 5S (1), the screen enters the shutdown interface (2) and all the indicators will turn off.
2. If the machine is not operated for a long time, it will automatically shut down after 1 hour of standby.
3. When the machine stops for no reason, please long press the main switch for 15S and then release, the machine will shut down and restart.

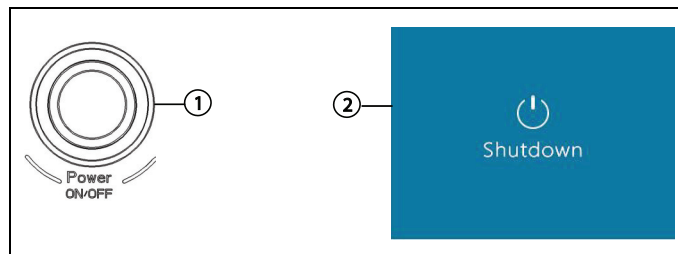

# Maintenance



**Dismantle the ZBP 2000 is prohibited. Please turn to the maintenance department if any failure.**

**Waterproof rating is IP55 (rain proof). Cleaning with high pressure washers, or similar equipment is prohibited.**

**Risk of Electric Shock. Do not remove cover. No user serviceable parts inside. Refer servicing to qualified service personnel.**

**Risk of Electric Shock. Connect only to properly grounded outlets. Risk of injury to persons. Do not use this product if the power cord or the battery cables are damaged in any way. This device is not intended for use in a commercial repair facility.**

**This device is intended for temporary use outdoors and reasonable care should be exercised when using this device in wet conditions.**

## MAINTENANCE SCHEDULE

Maintenance items	Every month	Every 3 months	Every 6 months	Every year
Check and clean the dust & sundries on the stainless steel dust screen at the back of the machine.	√			
Check and clean the dust of the display screen.	√			
Check whether the air outlet fan starts properly and clear the debris on the air outlet.	√			
Check whether the rubber on the top and bottom of the waterproof cover is aging.		√		
Check whether the rubber of the feet is aging.		√		
Check whether the overload protectors of the mains input and output sockets are damaged.			√	
Check the battery SOC and charge the battery.			√	
Check whether the screws of drawbar are loose.			√	
Check the plastic shell and handle for cracks.				√
Check whether the internal connector is loose and the cable is damaged.			√	
Discharging test			√	

Maintenance items	Every month	Every 3 months	Every 6 months	Every year
View alarm messages.		√		
Clean the debris or dust in the battery pack and inverter air duct inside the machine.			√	

Remarks:

1. If it is used in a worse environment and harsher conditions, these maintenance times need to be shortened accordingly.
2. Geographic location and environmental conditions.

## PERFORMANCE MAINTENANCE FOR BATTERY



Battery maintenance has to be done by professional or authorized personnel.

Battery maintenance needs to be operated after switching off the machine.

If the machine is not in use for 6 months or a long time, safety maintenance must be carried out and maintenance records must be made.

The details are as follows:

- 1) Check whether each power switch can be effectively switched on or off.
- 2) Check whether the overload protector is working effectively.
- 3) Check whether the internal cables are broken or softened and whether the connectors are effectively connected.
- 4) Check whether the internal channel of the battery pack is unblocked and has no blockage that cause poor ventilation.

## MAINTENANCE PLAN

### PROCEDURES FOR BATTERY MAINTENANCE

Maintenance items	Every month	Every 3 months	Every 6 months	Every year
Voltage check- Check whether the battery cell voltage is too high or too low on the phone interface.		√		
SOC check- Check whether the SOC of the battery is abnormal through the machine screen.		√		
History records check- View historical records on mobile phones to view exceptions, and analyse abnormal reasons.		√		
Overload protector check- Check whether the overload protectors are damaged.			√	
Cables check- Open the top cover and side plate of the machine, check whether the battery connector and cable are aged, broken & loose.			√	
Battery charging- Observe the battery level on the screen, charge the battery when it is low.			√	
Dust- Clean the dust and sundries between the gaps inside the battery to ensure smooth ventilation.			√	
Appearance- Check whether the output and input lines of the battery are clean, and whether there are overheating signs.			√	



